

## INDUSTRIAL GAS/AIR COMPRESSOR

OIL-FREE GAS OR AIR COMPRESSION TO 6,000 PSIG

### RIX INDUSTRIES' 4VX COMPRESSOR INCLUDES:

- One to Four Stages of Oil-Free Compression
- Air or Water Cooling
- Crosshead Construction
- Pressure-Lube Crankcase
- Continuous Duty
- Compact, Easy to Maintain Design

The RIX 4VX compressor features heavy-duty crosshead construction in a "V" cylinder arrangement with totally oil-free compression.

#### FEATURES

**Oil-free Operation.** RIX is a world leader in oil-free compression, having built thousands of oil-free compressors for demanding applications such as pure oxygen, nitrogen, argon, hydrogen, helium, CO<sub>2</sub>, and other mixed gases.

The 4VX uses gapless ring designs developed by RIX for maximum sealing and long life. Special ring materials are available for many different gases and performance requirements.

Optional piston rod seals provide capture of hazardous and rare gases.

#### Easy to Maintain

■ RIX's free-floating high pressure pistons allow for quick and easy ring changes.

■ Four con rods on the crankshaft allow each piston and cylinder to be serviced independently.

■ With oil-free operation, there are no oil separators to maintain, and no disposal of discharge oil.

#### Long Service Life

■ Moderate operating speeds reduce wear on moving parts.

■ Pressure-fed oil to the center main, rod bearings, and wrist pin bushings ensures long life of these critical components.

■ High capacity heat exchangers and moderate compression ratios keep cylinder temperatures low.

#### CONSTRUCTION

**Crankcase.** Pressure lubricated with shaft mounted gerotor oil pump and spin-on oil filter.

**Bearings.** Tapered roller main bearings; sleeve-type center main and con rod bearings; bronze wrist pin bushings.

#### SPECIFICATIONS

##### Horsepower:

10 to 50 BHP

##### Cylinders:

1 to 4 Stages, Oil Free  
4 " Stroke

##### Speed:

300 - 1100 RPM

##### Application:

Industrial gases/  
air/oxygen

**Cylinders.** Air-cooled aluminum with hardened stainless steel liners. Water cooled steel cylinders with field replaceable stainless steel liners optional.

**Piston Rings.** Piston and rider rings all self-lubricating TFE materials. High pressure stages use RIX patented spiral piston rings with a close tolerance floating piston for long life and quick replacement.

**Valves.** Stainless steel reed type with air-cooling. Plate or poppet with water-cooling.

**Heads.** Aluminum or stainless steel.



**RIX 4VX**  
Four Stage, Oil-Free  
Industrial Compressor



**RIX INDUSTRIES**  
4900 Industrial Way  
Benicia, CA 94510 USA  
707-747-5900 Phone  
707-747-9200 Fax  
www.rixindustries.com  
ISO 9001 CERTIFIED

# RIX 4VX SERIES

## SPECIFICATIONS

Inlet Pressure	Ambient Inlet			25 psig Inlet			100 psig Inlet*			500 psig Inlet*		
Performance	MAX. PRESSURE (PSIG)	MAX. FLOW (SCFM)	Motor HP	MAX. PRESSURE (PSIG)	MAX. FLOW (SCFM)	Motor HP	MAX. PRESSURE (PSIG)	MAX. FLOW (SCFM)	Motor HP	MAX. PRESSURE (PSIG)	MAX. FLOW (SCFM)	Motor HP
4-stage	5000	26	25	6000	45	40	N/A			N/A		
3-stage	1000 400	26 55	20 30	2000	60	40	6000	65	40	N/A		
2-stage	260 200	50 70	25 30	550	100	40	1800	100	40	6000	90	40
1-stage	55	110	30	160	180	40	500	180	40	2300	180	40

\* Nitrogen use - with underside of pistons vented to atmosphere

### STANDARD ACCESSORIES

- Steel Skid
- Electric Motor & V-belt drive
- Intercoolers & Aftercooler
- Cooling Air Shroud with Fan
- TENV Cooling Fan Motor
- Safety Switches
- Pressure Gauges
- Relief Valves
- Conversion Resistant Piping
- OSHA Beltguard

### TYPICAL PACKAGE OPTIONS

- Complete Control Panel with First-out Lights
- PLC Control
- Motor Starter
- Nema 4 or Nema 7
- Moisture Separators
- Purification Systems
- Pulsation Bottles
- Bypass Valve

### A LONG RECORD OF SUCCESS

Since 1878, RIX Industries has been engineering and manufacturing compressors for military, industrial and commercial applications. Over that long period of time, we've developed a world-wide reputation for producing and servicing a line of extraordinary, high quality products. Today, RIX compressors are providing reliable long-term service in such diverse installations as air separation plants, submarines, aircraft, steel mills and refineries.

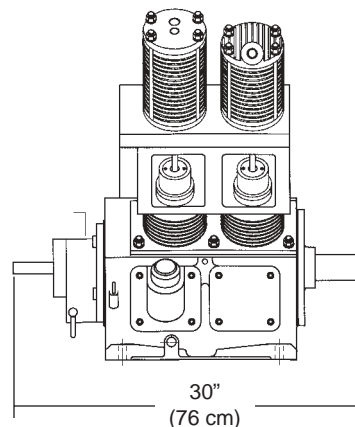
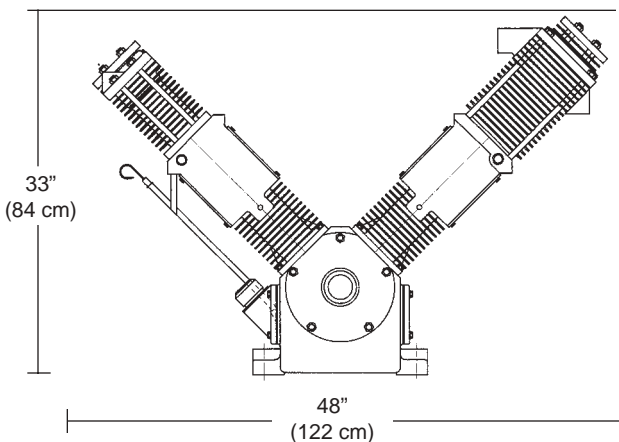

Bare Unit Weight: 750 lbs. (with flywheel) 340 kg  
 Typical Package Dimensions: 47"W x 84"L x 45"H; Weight - 2,100 Lbs.

### AVAILABLE FROM:



**RIX INDUSTRIES**  
 4900 Industrial Way  
 Benicia, CA 94510 USA  
 707-747-5900 Phone  
 707-747-9200 Fax  
[www.rixindustries.com](http://www.rixindustries.com)

ISO 9001 CERTIFIED