

RIX 2PS2B

HIGH PRESSURE
OXYGEN COMPRESSOR

for cylinder filling

Discharge Pressure to 2200 PSIG (152 BarG)

Flow Rate; .5 to 2.0 SCFM

(30 to 120 SCFH; .8 to 3.2 Nm³/H)

**RIX INDUSTRIES'
2PS2B FEATURES:**

- **Oil-Free Design**
- **Proven Safety Features**
- **Compact, Lightweight**
- **Low RPM for Long Service Life**
- **Continuous, Around-The-Clock Operation**

RIX Oxygen Compressors have been developed specifically for the exacting requirements of safe, reliable oxygen compression service. The 2PS2B Series incorporates design features developed over several decades for a variety of industrial and military oxygen compressor applications. These compressors are well suited for the compression of oxygen to 2200 psig, and other clean, dry gases to 2200 psig.

The RIX 2PS2B high pressure oxygen compressor will fill up to twelve (12) 240 cu. ft. 2200 psi cylinders in a 24 hour period.

2PS2B two-stage compressors employ two oil-free single-acting cylinders on a vertical opposed design crankcase. Heat exchangers, crankcase and compression cylinders are air cooled. The free-floating second stage piston allows the piston and rings to be easily changed. Replacement of the floating piston assembly typically requires only about 30 minutes. The ring life of the high pressure stage, at 2200 psig, has proven to be more than 2500 hours. Service life of the first stage is considerably longer.



The RIX 2PS2B high pressure oxygen compressor will fill up to twelve (12) 240 cu. ft. 2200 psi cylinders in a 24 hour period.



RIX INDUSTRIES
6460 Hollis Street
Oakland, CA 94608 USA
Phone (510) 658-5275
Fax (510) 428-9102

RIX 2PS2B Oxygen Compressor

Size, Compressor Pkg. 29"H x 23"L x 14"W
 (74Cm x 58Cm x 36Cm)
Weight, Compressor Pkg. 150 lbs. (68 Kg)
Power, motor size 3/4 HP or 1.5 HP (.6 or 1.1 Kw)
 120 or 240 volts
 50 or 60 Hz as required
 single phase
Compressor RPM 190 or 390 RPM
Suction Pressure 30 - 70 PSIG
 2 - 5 BarG
 2 - 5 Kg/cm² G
Max. Discharge pressure, O₂ 2200 PSIG
 152 BarG
 155 Kg/cm² G
Flow Rate 30 - 120 SCFH
 .80 - 3.20 Nm³/H
 14 - 57 Nltr/M
Cooling air cooled
Shipping weight 200 lbs. (91 Kg)
Shipping volume 36"H x 30"L x 24"W
 (91Cm x 76Cm x 61Cm)
Gas inlet 1/4" FPT
Gas outlet 1/4" FPT

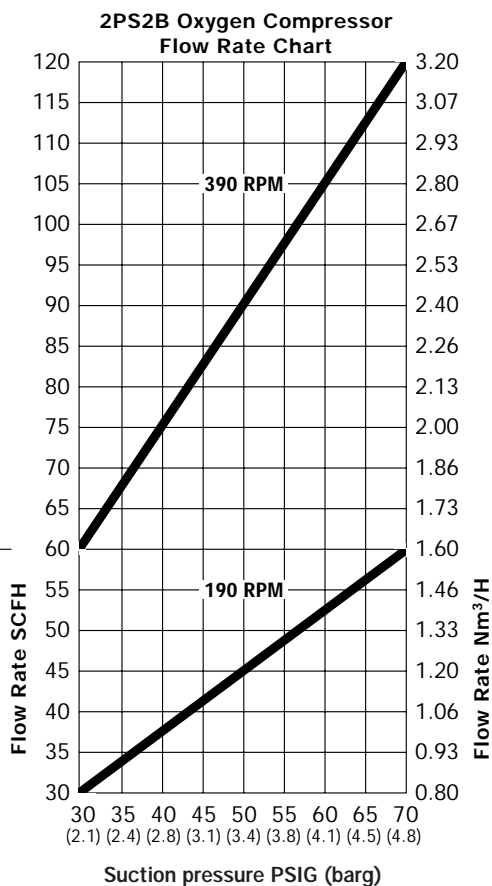
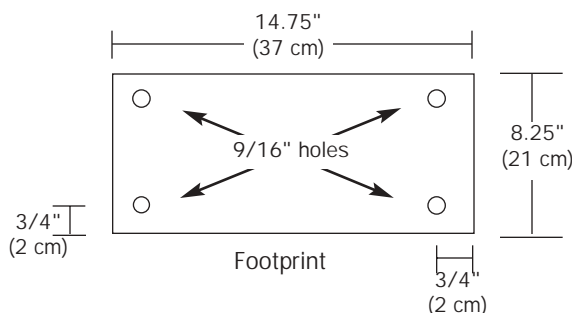
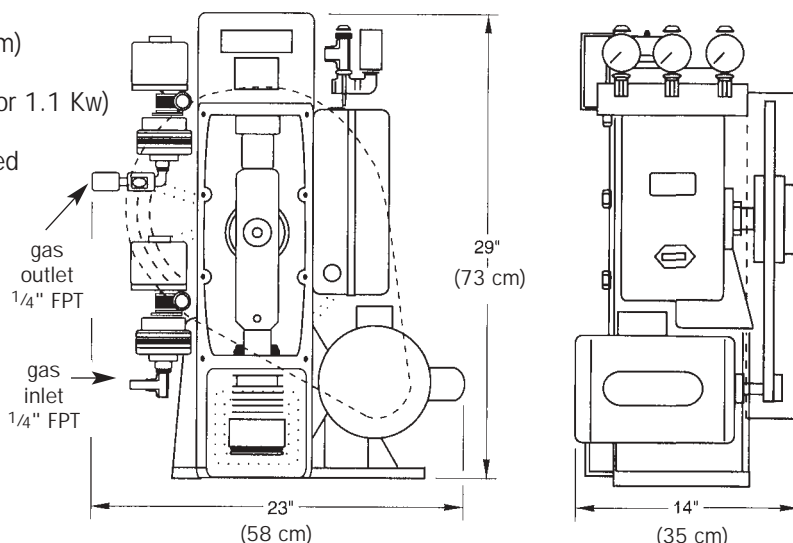

STANDARD COMPONENTS

Compressor Package:

- Compressor
- Motor
- Starter
- Start/Stop Buttons
- Hour Meter
- High Pressure Shutdown
- Low Inlet Pressure Shutdown
- Relief Valves
- Pressure Gauges
- Drive Belt
- Belt Guard
- Oxygen Clean
- Cooling Fans (H Models only)

Models:

2PS2B-L	³ / ₄ hp.....	120V/60hz/1ph.....	30-60 scfh
2PS2B-L50	³ / ₄ hp.....	240V/50hz/1ph.....	30-60 scfh
2PS2B-H	1½ hp	120V/60hz/1ph.....	60-120 scfh
2PS2B-HH	1½ hp.....	240V/60hz/1ph.....	60-120 scfh
2PS2B-H50	1½ hp.....	240V/50hz/1ph.....	60-120 scfh

RIX INDUSTRIES

6460 Hollis Street
 Oakland, CA 94608 USA
 Phone (510) 658-5275
 Fax (510) 428-9102

